

## APPLICATIONS:

Horizontal Laminar Flow Benches can be used for many different applications that require a controlled, clean environment at the benchtop level. These Benches are free standing and self contained with optional isolated table work surface. Benches can be used in situations where it is not feasible or cost effective to build a cleanroom. In many cases, it would be advantageous to use clean benches to establish class 100 clean zones rather than build or upgrade a cleanroom.

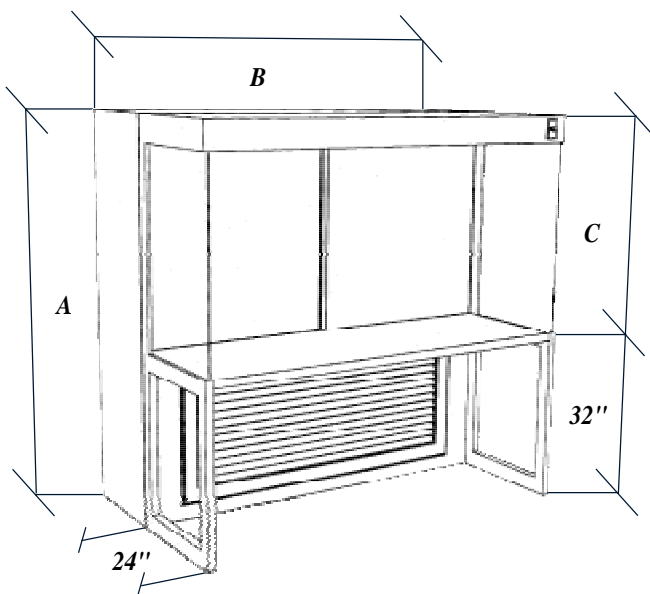

## CONSTRUCTION:

**Frame:** 16 gauge Cold Rolled Steel with Gloss White painted Enamel finish.

**Cabinet:** White HPL laminated High Density Particleboard.

**Side Panels:** Removable clear Acrylic Plastic.

**Work Surface:** White High Pressure Laminate.

**Blower and Motor:** Energy efficient and engineered for acoustics Rated at twice the initial static-pressure to maintain the required 100 feet per minute. Includes Speed Control switch.

**Prefilters:** 30% efficiency, one inch thick, Pleated type, with access from front of unit.

**Final filters:** Hepa type 99.99% efficiency on all particles 0.3 Microns and larger in Aluminum frames with access from back.

**Lighting:** Fluorescent with minimum 125 F.C. at surface.

**Electrical:** Standard 115 volts. [230v and 460v 3PH available]

**Options:** Antistatic materials, Stainless Steel work surface, Magnahelic gauges, .12 Micron ULPA Filters, Isolated work surface.

Specifications are subject to change without notice.

Model Number	Dimensions			Approx. wt. lbs
	A	B	C	
HZL-5024	61"	50"	23"	475
HZL-5030	67"	50"	29"	500
HZL-5036	73"	50"	36"	575
HZL-5048	85"	50"	47"	800
HZL-6024	61"	74"	23"	575
HZL-6030	67"	74"	29"	725
HZL-6036	73"	74"	36"	875
HZL-6048	85"	74"	47"	1075
HZL-8024	61"	98"	23"	775
HZL-8030	67"	98"	29"	975
HZL-8036	73"	98"	36"	1175
HZL-8048	85"	98"	47"	1350

[custom sizes available on request]